



Troubleshooting Cell Sites on the Ground with CellAdvisor

An RFoCPRI interference analyzer for remote radio heads

Evolving base stations have implemented cloud radio access network (C-RAN) technology to provide better planning flexibility and meet demands for ultra-high data throughput. A base station consists of two key units: the baseband and radio modules. C-RAN enables separating them so that radio units can be mounted remotely on a pole or wall and the baseband unit can be deployed in a concentrated central location, typically called a baseband hotel. The fiber link between the baseband and radio units can extend over tens of kilometers.

Introducing C-RAN reduces CapEx while satisfying the demand for higher data rates. Where radio units are installed at the top of a tower close to the antenna to maximize the RF link budget, technicians have to climb the tower to troubleshoot any radio-unit issues. This increases maintenance costs and also brings up safety issues.

Background

A Tier-1 operator in India installed a LTE-TDD network using a key network equipment manufacturer's (NEM) eNode-B. The digital baseband unit was separated from the radio unit and connected through a common public radio interface (CPRI)-based fiber link. CPRI is the successful industry specification standard for the key internal interface of radio base stations between the radio equipment control (REC) and the radio equipment (RE). During the initial verification, uplink sensitivity was a key issue preventing the completion of commissioning.

Two possible root causes for high received signal strength indications (RSSI) were assumed:

- High thermal noise — an internal issue related to the RRH and/or the antenna system
- External interference — requiring pinpointing and hunting interference

Unmet Need

Quickly and easily identifying radio link issues such as interference is a big challenge for the entire RF industry. Customers require tools that can quickly isolate interference issues and help quickly turn up cell sites. In this case, the operator and NEM initially considered hunting for interference at the ground using a YAGI antenna and a handheld spectrum analyzer. However, this methodology does not address issues related to internal interference such as PIM or hardware problems. After trying the Yagi antenna, it was determined that the source of the high noise rise was internal to the cell site.

The NEM then considered installing a 30 m long RF cable to connect to the RX monitoring port of the RRH, at the top of the tower. Since the feasibility of this solution—the cable install and a tower climb—was questionable, the operator and NEM reached out to Viavi Solutions® to help identify the root cause of high RSSI at the base station.



Figure 1. Upgrading a cell tower with FTTH

The VIAVI Answer

Working with the NEM, Viavi proposed an RfCPRI test solution for identifying both internal and external interference issues. One of the key benefits of the RfCPRI interference analyzer function for LTE-TDD systems is that it does not require a gated sweep with an external clock. This contrasts with a spectrum analyzer plus YAGI antenna solution. The CPRI link delivers uplink and downlink signals with two separate fiber links, so RfCPRI can work with either one of the links selectively.

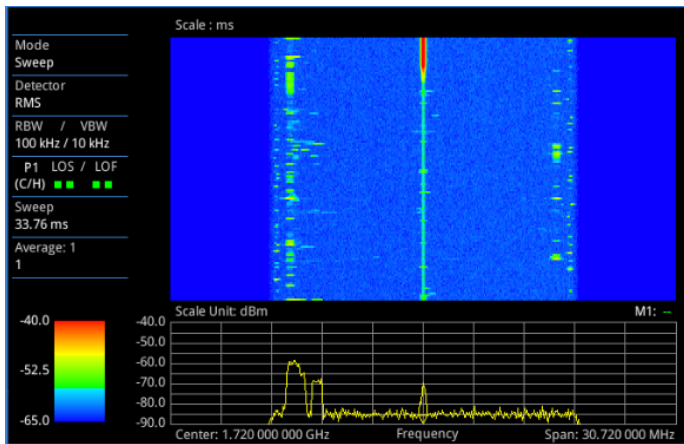

Figure 2. CellAdvisor showing external RF interference

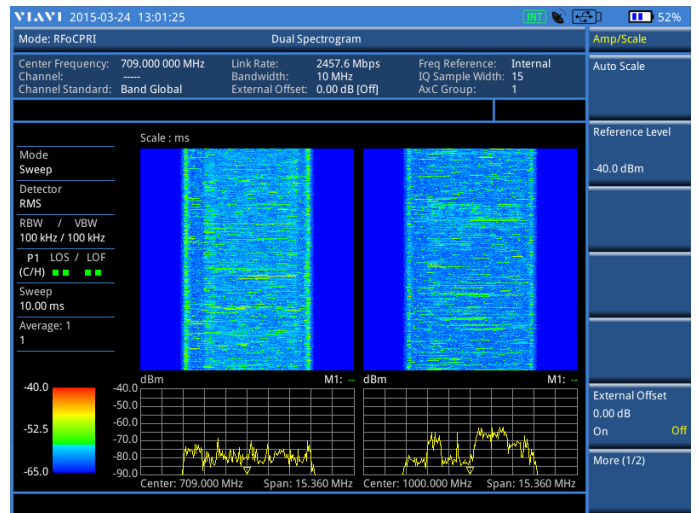

Figure 3. RF interference across the band

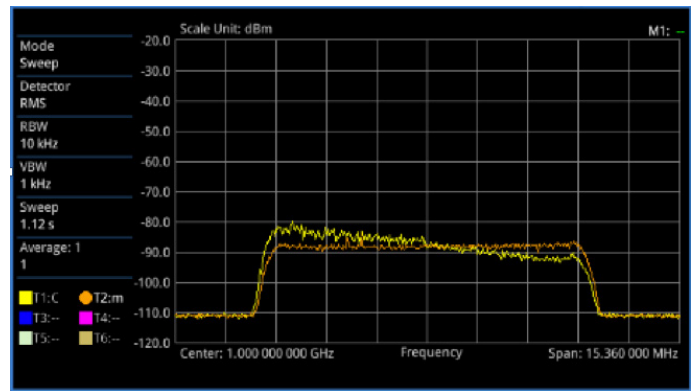

Figure 4. PIM detection

Additionally, the CellAdvisor RfCPRI feature simultaneously detects PIM-related issues as shown in Figure 4.

RFoCPRI can determine interference without any calibration, but the noise figure of every radio manufacturer is different. To determine the noise floor of an RRH, it is essential to do some baseline measurement for that manufacturer's RRH either in the lab or on a good working cell site. This testing process requires determining an offset between the RFoCPRI spectrum reading and the RF spectrum reading.

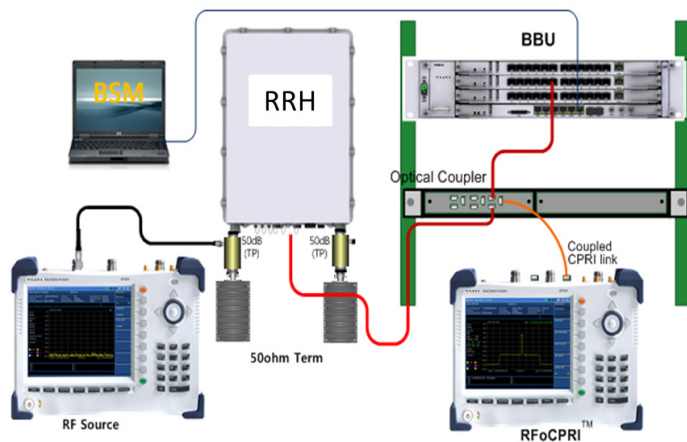

Figure 5. Calibration procedure

Calibration Configuration and Testing

The calibration procedure consists of four steps:

1. Inject a CW signal to the EQP coupling port of the RRH using CellAdvisor in the lab or on a good RRH cell site.
2. Read the RSSI being reported to the connected BBU at the base station module (BSM) for a baseline measurement.
3. At the test cell site, measure RSSI using either the RFoCPRI interference or RF analyzer.
4. Calculate the offset between the CellAdvisor (step 3) and the BBU readings seen at the BSM (step 2).

If the above offset measurement shows an abnormal noise rise, the RRH is the root cause of the problem.

Summary

Using the CellAdvisor RFoCPRI feature, the operator and NEM successfully determined the root cause of the noise rise at the cell site. No tower climb was needed, and after replacing the radio, they commissioned the cell site.



Contact Us **+1 844 GO VIAVI**
(+1 844 468 4284)

To reach the Viavi office nearest you,
visit viavisolutions.com/contacts.

© 2016 Viavi Solutions Inc.
Product specifications and descriptions in this
document are subject to change without notice.
celladvisor-troubleshoot-cs-cpo-nse-ae
30179610 000 0116